

# PulseQ

AC Home **EU Version**

TOPDON



**AC EV Charger**  
User Manual



# Contents

Abbreviations	.....	3
Section 1—PRECAUTIONS	.....	4
Section 2—STANDARDS COMPLIANCE	.....	7
Section 3— PRODUCT OVERVIEW & INFO	.....	9
Section 4—What's in the Box?	.....	13
Section 5—Installation	.....	14
Section 6—Network Configuration	.....	24
Section 7—LED Indicators	.....	30
Section 8—Fault Handling	.....	31
Section 9—Warranty	.....	32

# Abbreviations

S/N	Abbreviations	Description
1	IEC	International Electrotechnical Commission
2	EV	Electrical Vehicle, this can be BEV (battery EV) or PHEV (plug-in hybrid EV)
3	EVSE	Electric Vehicle Supply Equipment <b>[IEC61851-1]</b>
4	OBC	On-board charger (of an EV)
5	KW	Kilo Watt (unit of Power)
6	A	Ampere (unit of Current)
7	V	Volt (unit of Voltage)
8	Hz	Hertz (unit of Frequency)
9	LCD	Liquid Crystal Display
10	LED	Light-emitting Diode
11	CMS	Central Management System, manages EVSE and has the information for authorizing users for using its EVSE.
12	OCPP	Open Charge Point Protocol A standard open protocol for communication between EVSE and a Central System and is designed to accommodate any type of charging technique. ( <a href="http://www.openchargealliance.org">www.openchargealliance.org</a> )
13	HMI	Human-Machine Interface

# Section 1—PRECAUTIONS

## 1.1 IMPORTANT SAFETY PRECAUTIONS



**WARNING-** When using electric products, basic precautions should always be followed, including the following. This manual contains important instructions for Models and PULSEQ AC HOME that shall be followed during the installation, operation, and maintenance of the charging station.

1. Read all the instructions before using this product.
2. This device should be supervised when used around children.
3. Do not put fingers into the electric vehicle connector.
4. Do not use this product if the flexible power cord or EV cable is frayed, has broken insulation, or has any other signs of damage.
5. Do not use this product if the enclosure or the EV connector is broken, cracked, open, or shows any other indication of damage.
6. Indicate the ambient temperature rating, (-30°C to 55°C ).
7. **"CAUTION" and the following or equivalent:** "To reduce the risk of fire, connect to a circuit provided with maximum branch circuit overcurrent protection of 40A 1-Phase/20A 3-Phase/40A 3-Phase in accordance with electrical code."

Model	Current Rating
PulseQ AC Home_7K_EU	40A 1-Phase
PulseQ AC Home_11K_EU	20A 3-Phase
PulseQ AC Home_22K_EU	40A 3-Phase

## 1.2 SAFETY NOTES

### 1.2.1 Safety signs used

The following warning signs, mandatory signs and information signs are used in this manual, on and in the AC EV Charger.



CAUTION: Warning of electrical hazards.

This sign is intended to alert the user that severe personal injury or substantial property damage can result if the device is not operated as requested.



ATTENTION: Warning of a dangerous spot or dangerous situation.

This sign is intended to alert the user that minor personal injury or material damage can result, if the device is not operated as requested.



CAUTION: Do not touch by hands in case of ESD.

Indicates the possible consequences of touching electrostatically sensitive components.



No access for unauthorized persons.



Use protective footwear.



Must wear a safety helmet.



Indicates important texts, notes, or tips.

### 1.2.2 Safety Precautions for Installation



Safety protection must be done when installing the EV Charger.

Installation must be carried out by personnel with professional qualification, otherwise there is a risk of electric shock.

It shall be installed in the place without violent vibration and impact, and placed vertically to facilitate ventilation.

It shall be installed on noncombustible materials, or there is a risk of fire.

Do not drop any foreign objects, especially metal objects, into the inside of the Charger or there is a risk of fire.

The lead nose of the Charger must be securely attached or there is a risk of damaging the equipment.



### 1.2.3 Safety Precautions for Maintenance



Personnel must always use protective footwear when maintenance work.



It is recommended that routine safety inspection visits to Charger be conducted at least once a week. Do not put inflammable, explosive, or combustible materials, chemicals, combustible steam, and other dangerous goods near the Charger, otherwise there is a risk of fire.



Keep the charging adapter clean and dry and wipe with a clean, dry cloth if soiled. Do not touch the Charger with your hand when charged.

### 1.2.4 Safety Precautions for Maintenance



Strictly forbidden for minors or persons of restricted capacity to approach the Charger to avoid injury. Forced charging is strictly forbidden when the electric vehicle or Charger fails.



The electric vehicles can only be charged with the engine off and stationary. Do not charge in rainy and thunderous weather. It is strictly prohibited to use the charger when the charging adapter or charging cables are defective, cracked, worn, broken or the charging cables is exposed. If you find any, please contact the supplier in time.

# Section 2—STANDARDS COMPLIANCE

## 2.1 Standard(s) for safety

Conform to IEC 61851, IEC 62196

## 2.2 Charging mode and connection

According to IEC 61851-1, the Charging mode of PulseQ AC Home is Mode 3, and charging connection is the Case C.

Mode 3

a method for the connection of an EV to an AC EV supply equipment permanently connected to an AC supply network, with a control pilot function that extends from the AC EV supply equipment to the EV.



Case C:

Connection of an EV to a supply network utilizing a cable and vehicle connector permanently attached to the EV charger.

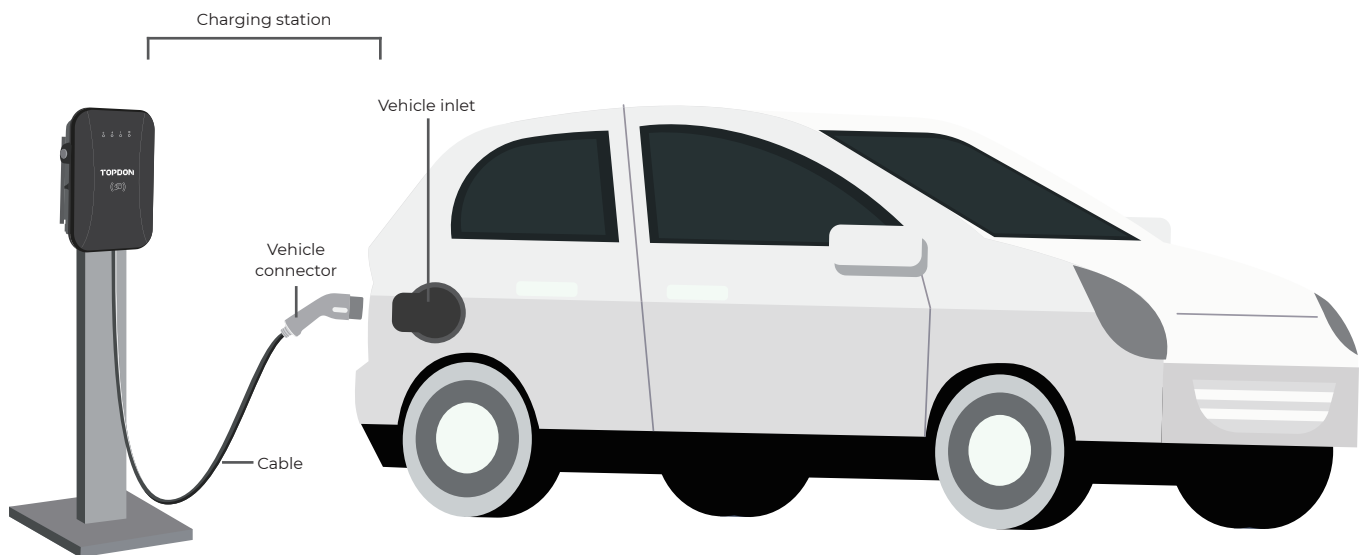

## 2.3 Charging interface

The charging plug of PulseQ AC Home product meets IEC 62196-2, Type 2.

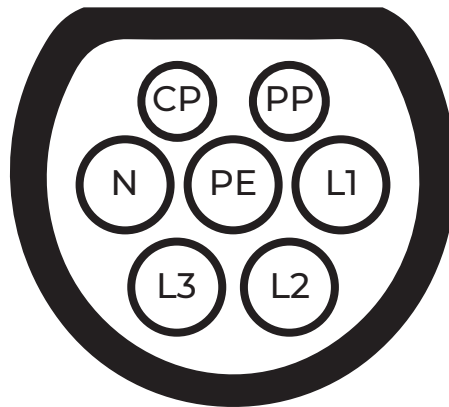

Fig. 2.3.1 Schematic diagram of Type 2 interface

PulseQ AC Home provides a Type 2 female plug with charging cable, it only charging an EV with a Type 2 charging socket (vehicle inlet).



# Section 3—PRODUCT OVERVIEW & INFO

## 3.1 Shape & Dimensions

The shape & dimensions of PulseQ AC Home charger are shown as Fig. 3.1.1

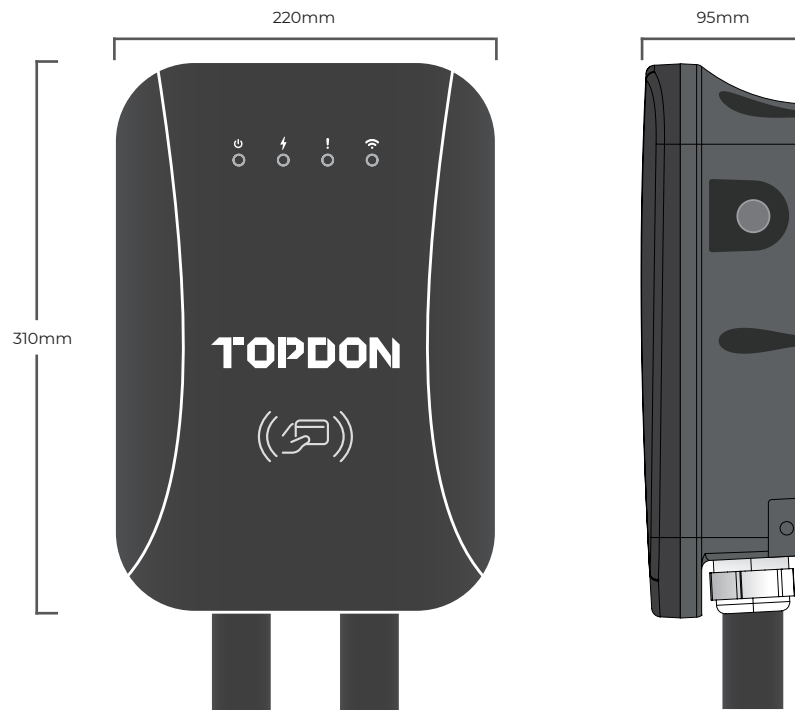
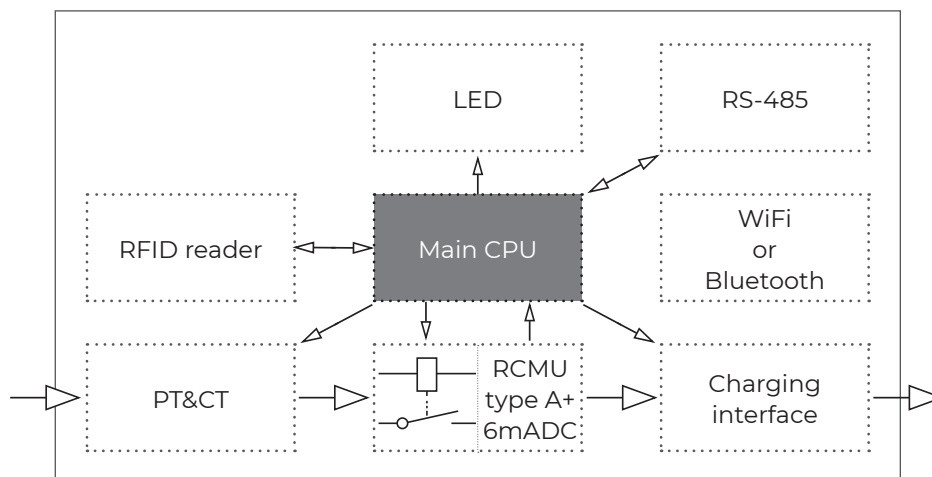

Fig. 3.1.1 The shape & Dimensions of PulseQ AC Home

## 3.2 Block diagram

The block diagram of PulseQ AC Home charger is shown as Fig. 3.2.1



It is widely used in various household electric vehicle charging in Europe, as well as various chargers, parking lots, community garages and public electric vehicle charging places.

## 3.3 Specifications

### 3.3.1 Electrical Specifications

<b>Model Number</b>	<b>PULSEQ AC HOME</b>
Rated Voltage	230V/400V, 50/60Hz
Rated Current	32A 1-Phase/16A 3-Phase/32A 3-Phase
Rated Power	7kW/11kW/22kW
Charging Interface	IEC 62196-2, Type 2 plug with 5m cable/IEC 62196-2, Type 2 optional plug with 7.5m cable Note: That cord extension sets are not be used.

### 3.3.2 Functional Description

Charging Mode	Mode 3
Charging Control	Remote: APP-controlled
	Local: Plug and charge
	RFID Reader mode
Indicator Lights	4 LED lights;
	Indicate 4 statuses include standby, charging, fault, and network
Communication Interface	WiFi(2.4GHz/5GHz)
	And support OCPP 1.6J Protocol (Optional)
Communication Interface (Optional)	RS-485 with special communication protocol
Safety Protection	Surge protection, over temperature, over/under voltage, over current, ground protection
RCD Built-in	RAMU, Type A $I\Delta n=30mA + I\Delta dc=6mA$

### 3.3.3 Mechanical Parameters

Mounting	Wall-mounted
Net Weight	≤ 7KG (5m cable) 、 ≤ 9KG (7.5m cable)
Dimension	H×W×D = 310mm × 220mm × 95mm
Color & Material	Front cover: Gray, PC; Back cover: Black, PC
IP Code	IP65
IK Code	IK10

### 3.3.4 Ambient Conditions

Altitude	≤ 2000m
Storage Temperature	-40 ~ 75°C
Operation Temperature	-30 ~ 55°C
Relative Humidity	≤ 95%RH, no water droplet condensation
Vibration	< 0.5G, no acute vibration and impaction
Installation Location	Indoor or outdoor, good ventilation, no flammable, explosive gases

### 3.3.5 Nameplate



- 1.This equipment should be reliably grounded before use.
- 2.Installation, wiring and maintenance should be done by personnel with professional qualification.
- 3.Do not expose to flammable gas.
- 4.Failure to read user manual carefully before use may lead to improper operation.

Model No.:	PulseQ AC Home_7K_EU PulseQ AC Home_11K_EU PulseQ AC Home_22K_EU
Rated Voltage:	230V/400V, 50/60Hz
Rated Current:	32A 1-Phase/16A 3-Phase/32A 3-Phase
Rated Power:	7kW/11kW/22kW
IP code:	IP 65
Temperature Rating:	-30~55°C(-22~131°F)



# Section 4—What's in the Box?

<b>a.</b> AC EV Charger (5m charging cable)	1
<b>b.</b> Charging Dock	1
<b>c.</b> Wall-mounting Accessories	1
<b>d.</b> User Manual	1
<b>e.</b> Quick User Guide	1
<b>f.</b> Quality Certificate	1
<b>g.</b> Wall Installation Template	1
<b>h.</b> M6×63mm Expansion Bolt	4
<b>i.</b> M5×40mm Expansion Bolt	4
<b>j.</b> Charging Dock Installation Template	1
<b>k.</b> IC card	2



**a**



**b**

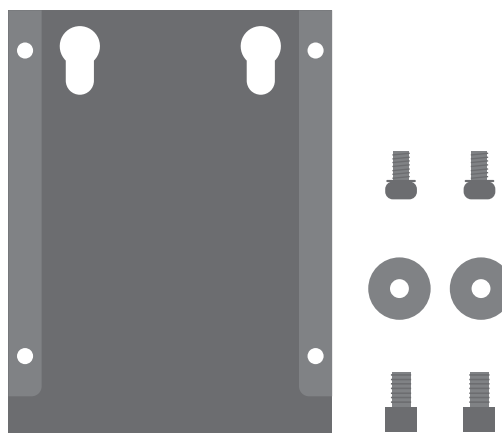

**c**

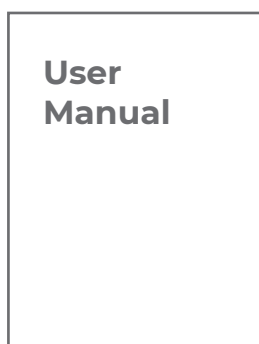

**d**



**e**



**f**

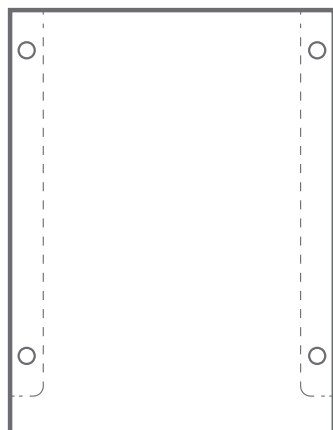

**g**

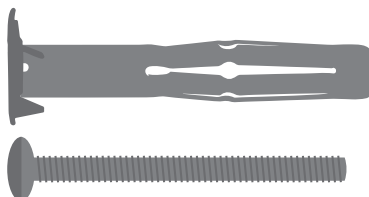

**h**

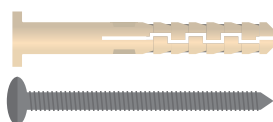

**i**

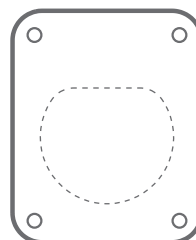

**j**



**k**

# Section 5—Installation

## 5.1 Pre-Installation Inspection

When unpacking, please carefully confirm the following points:

- Whether the accessories are missing according to the packing list.
- Whether there is any damage during transportation.
- Whether the model and specification of the machine's nameplate are consistent with the order requirements.



▷ If any damage or missing parts are found, please do not start the installation, and contact us as soon as possible.



▷ Please keep the packing box and packing materials for 1 month for future handling.  
▷ The paper packaging is recyclable.

## 5.2 Pre-work Preparation

- When transporting or moving the EV charger, pay attention to the following points to ensure product safety:



▷ This product is electrical equipment. It should be handled with care to avoid violent vibration and impact.  
▷ The charger shall not be transported by dragging the charging connector and the charging cable.

- In order to ensure the long-term stable operation of the product, it is recommended to avoid installing chargers in extreme weather as far as possible, especially the low or high ambient temperatures may affect the installation effect due to thermal expansion and cold contraction.
- Space requirement: When the charger is fixed on the wall, the minimum space requirements are shown in Fig. 5.2.
- It is suggested that the charger should be installed in a place with good ventilation, no direct sunlight and shelter from wind and rain. In order to ensure good ventilation condition, you should mount the charger vertically and leave enough space.

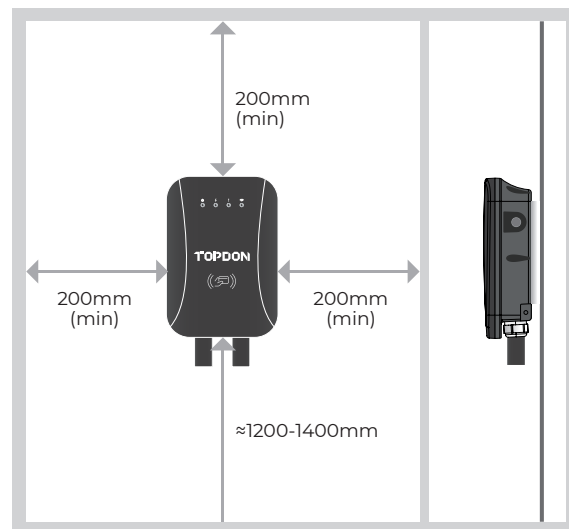
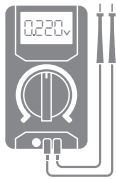
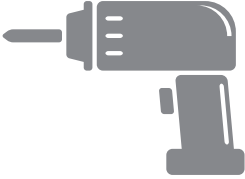

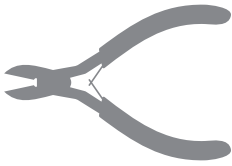
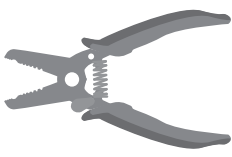
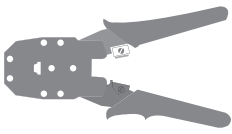



Fig. 5.2 Minimum space requirements for wall mounting

## 5.3 Tools for Installation

Please prepare the following tools before installation

No.	Tools' Name	Schematic Picture	Main Uses
1	Multimeter		Check the electrical connection and measure the voltage
2	Electric Impact drill		Drill fixing holes in the wall
3	Wrench		Fastening bolt
4	Diagonal plier		Cut the cable
5	Wire stripper		Peeling cables
6	Crimping plier		Pressed cable terminal
7	Cross screwdriver		Fastening screw

## 5.4 Wall Bracket Installation

Ensure the homeowner has chosen an installation location that allows the charging cable to reach the car's charging port while still providing slack. Ensure there is a stud available at the desired location for mounting the charging station. (See Fig. 5.4.1) Ensure there is WiFi signal available.



Fig. 5.4.1



**WARNING:** In areas with frequent thunderstorms, add surge protection at the service panel for all circuits. Ensure all power and ground connections, especially those at the breaker and bus bar, are clean and tight. Remove all oxide from all conductors and terminals before connecting wiring.

1. Refer to the Fig. 5.4.2 to understand the dimensions of the wall bracket. Please make sure the space on the wall is at least 5.62" x 5.98" (143mm x 152mm).

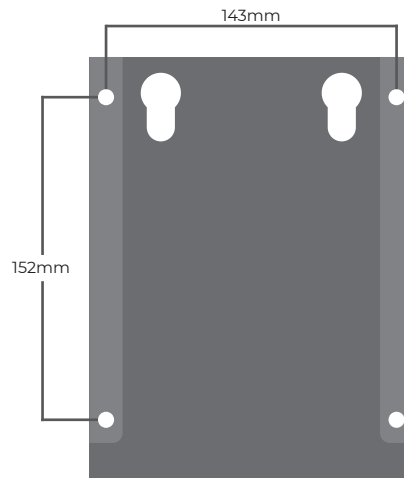

Fig. 5.4.2



2. Mark the mounting hole on the wall with the installation template. (See Fig. 5.4.3)

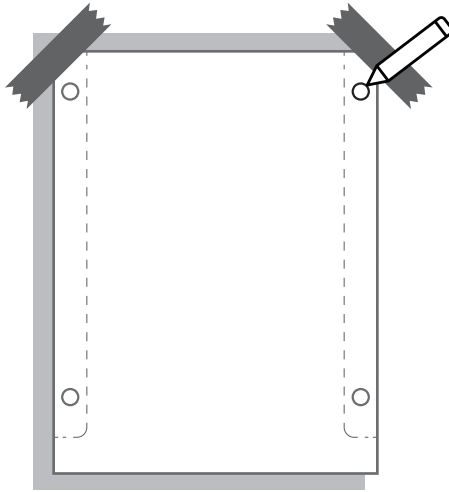

Fig. 5.4.3

3. Drill the mounting holes on the wall with a depth of at least 1.97". (See Fig. 5.4.4)

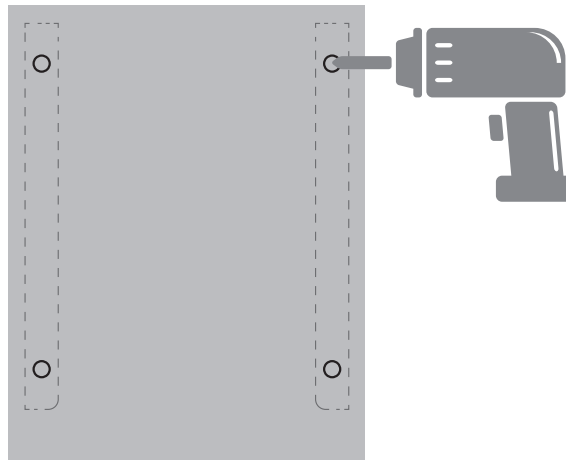

Fig. 5.4.4

3. Hammer the expansion sleeve into the corresponding hole (See Fig. 5.4.5)

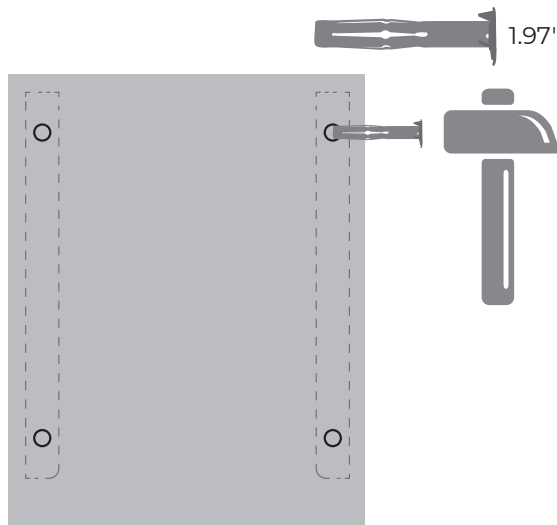

Fig. 5.4.5

5. Fix the bracket to the wall with the expansion screws (See Fig. 5.4.6) included in the package.

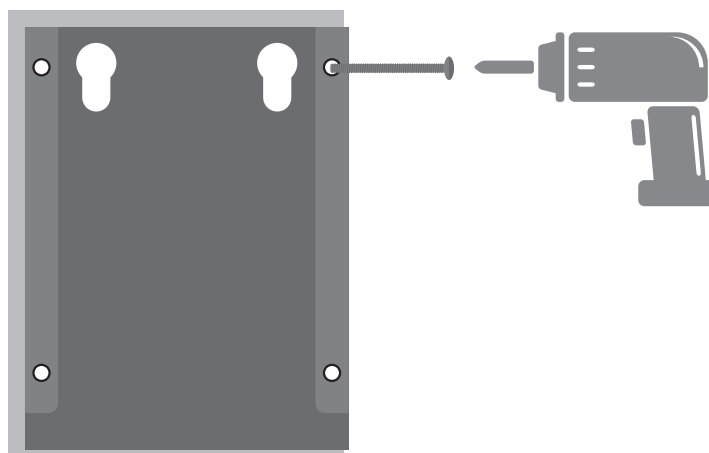

Fig. 5.4.6

6. Attach the charger to the bracket.(See Fig. 5.4.7)

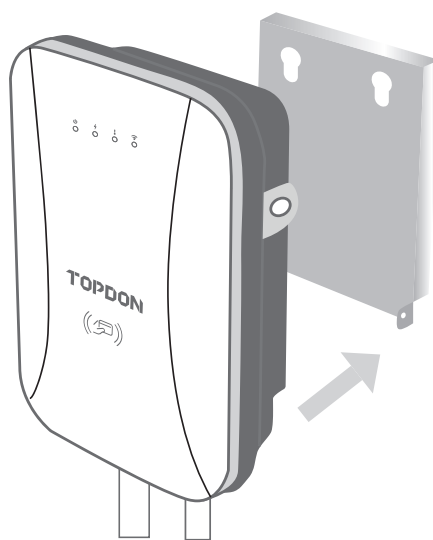

Fig. 5.4.7

## 5.5 Hardwire Installation



▷ The hardwire installation needs to be done by electricians, and please strictly follow the safety precautions.

1. Unscrew the six screws on the back cover with a Phillips screwdriver, and remove the front cover. (See Fig. 5.5.1)

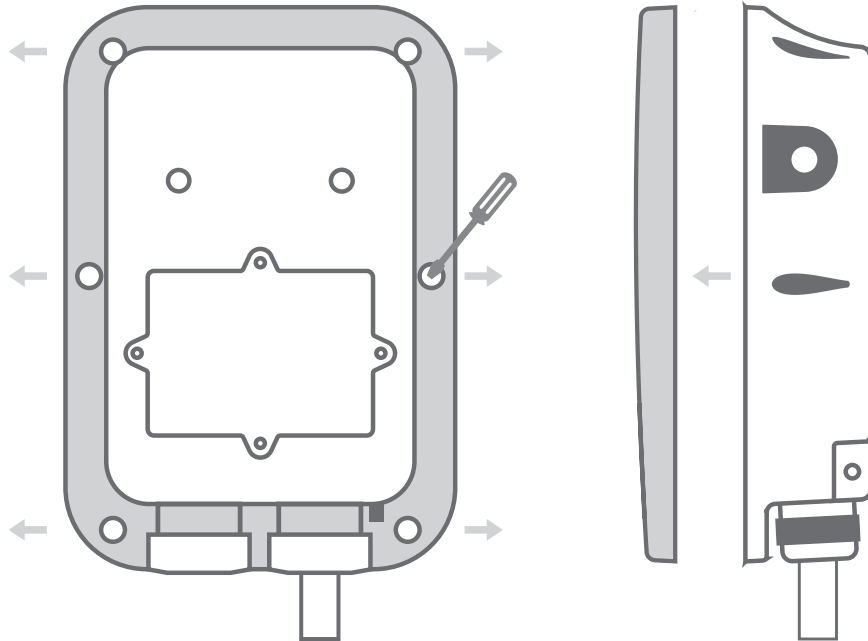

Fig. 5.5.1

2. Unscrew the gland at the bottom of the charging station. Pass the prepared power cable through it. (See Fig. 5.5.2)

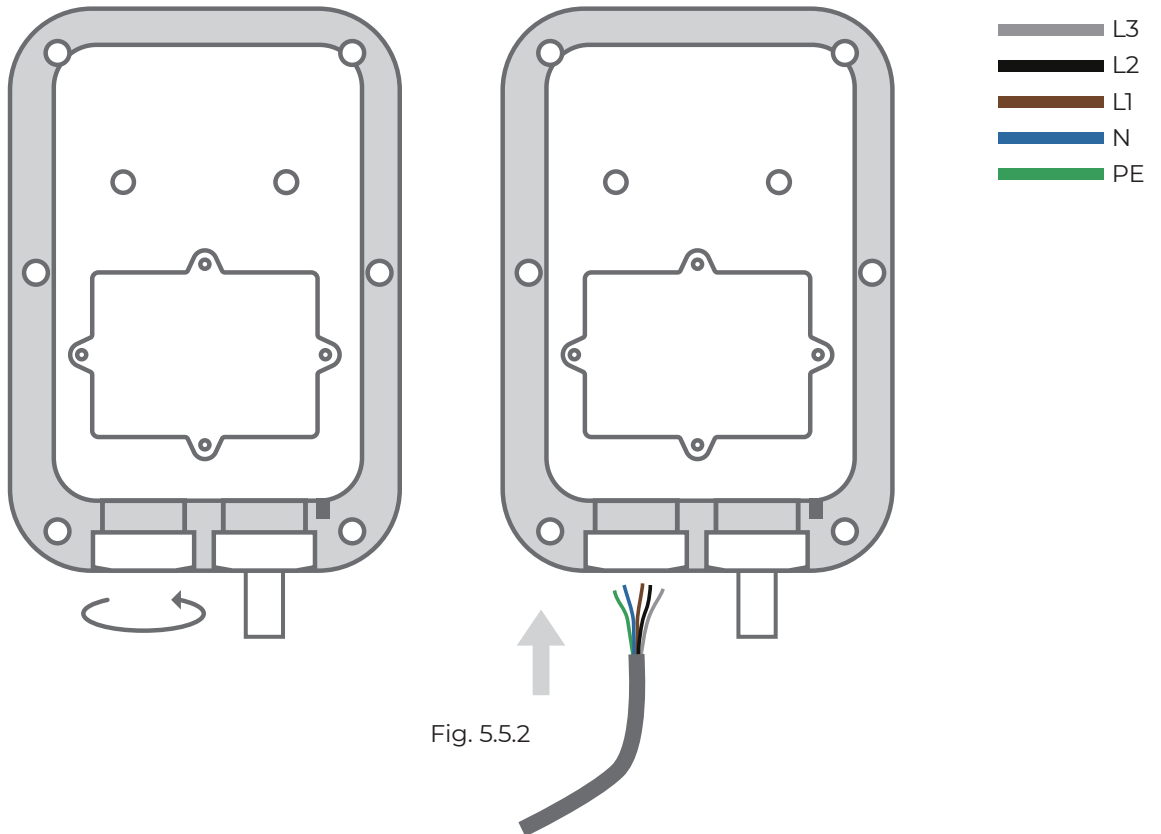

Fig. 5.5.2

3. Use a wire stripper to remove 10~12 mm of insulation from the wire conductor. (See Fig.5.5.3)

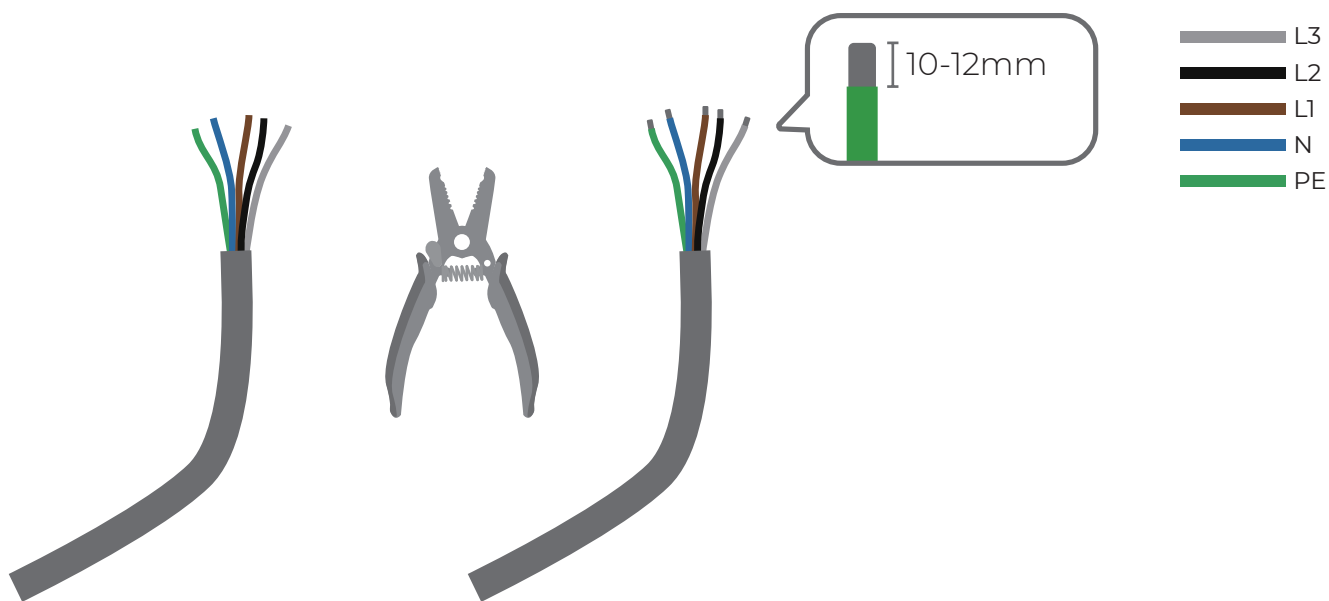

Fig. 5.5.3

4. Turn over the wirebox. Loosen the five screws with a flat-blade screwdriver and fully insert the wire conductors into the connectors on the terminal block. Tighten the screws and make sure each wire conductor is securely connected. (See Fig.5.5.4)

**Note:** For the model of PulseQ AC Home\_7K\_EU, only connect the corresponding wire conductors to the L1, N, PE connectors.

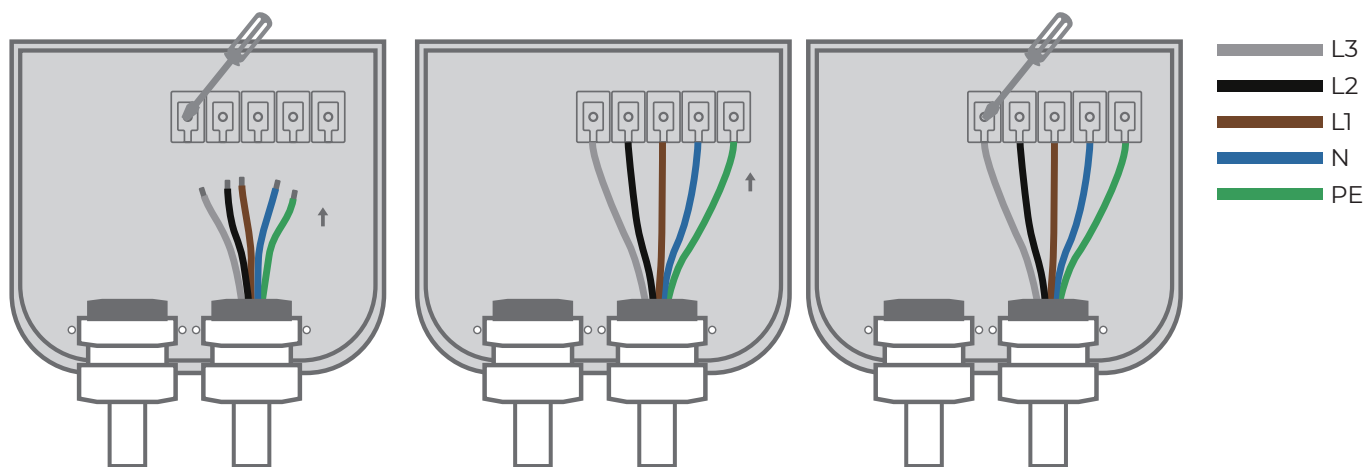
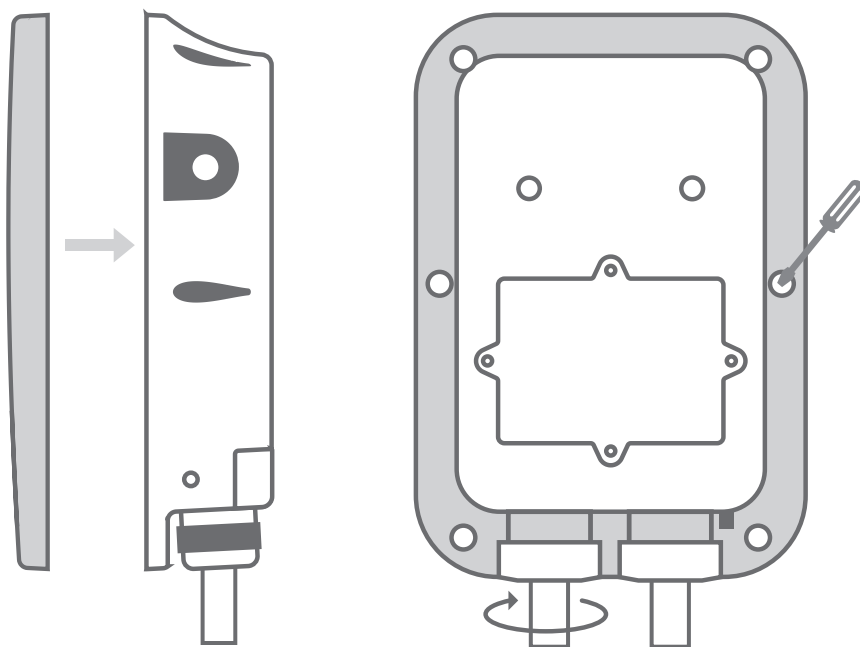

Fig. 5.5.4

5. Reinstall the front cover and tighten the gland.



## 5.6 Charging Dock Installation

1. Please make sure the space on the wall is at least 2.12" × 2.12" (54mm × 54mm).

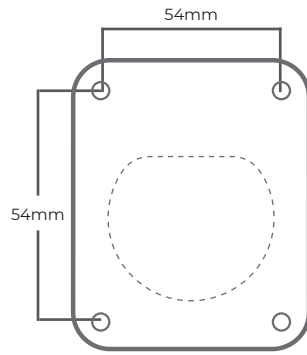

2. Place the installation template on the wall and mark the mounting hole. (See Fig. 5.6.1)

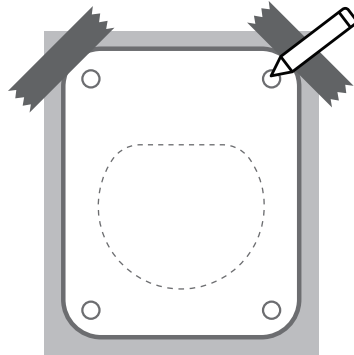

Fig. 5.6.1

3. Drill the mounting holes on the wall with a depth of at least 1.97". (See Fig. 5.6.2)

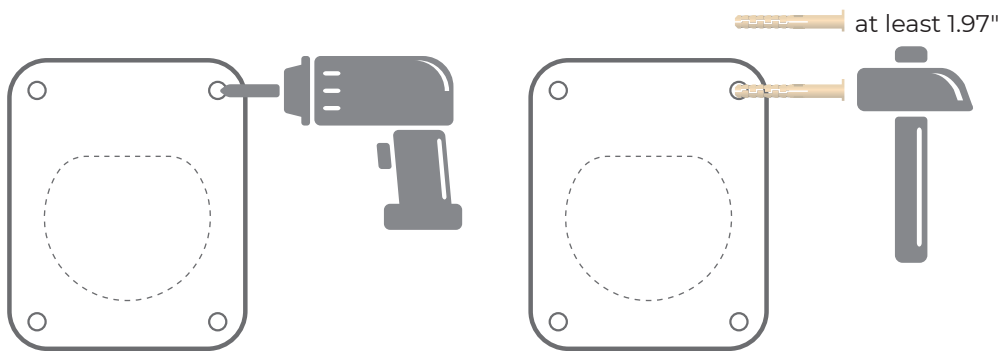

Fig. 5.6.2

4. Fit the charging plug socket into the charging dock (See Fig. 5.6.3)

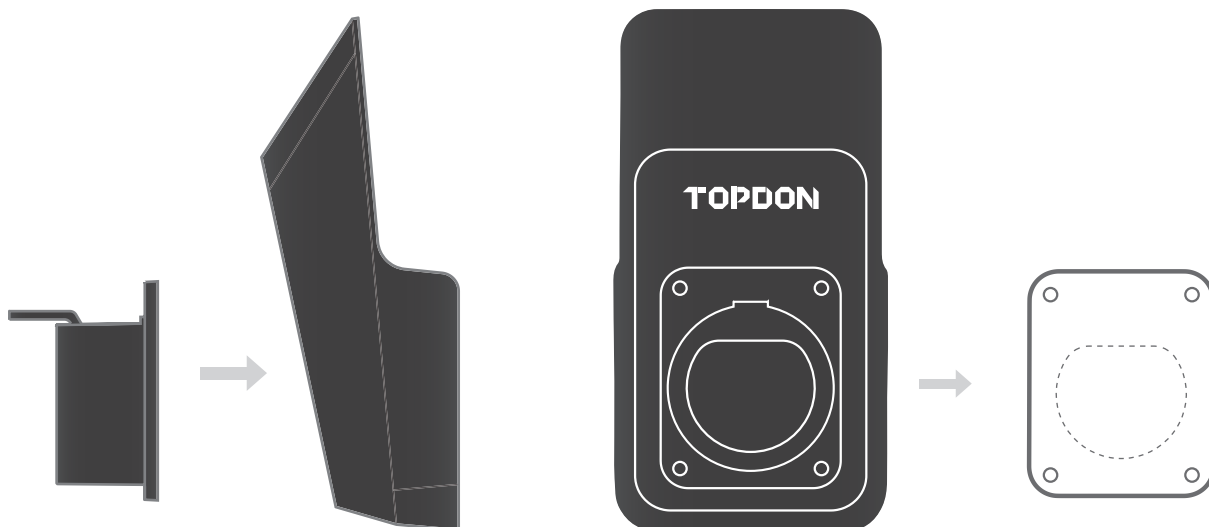

Fig. 5.6.3

5. Fix the charging dock on the wall with the expansion screw in the package. (See Fig. 5.6.4)

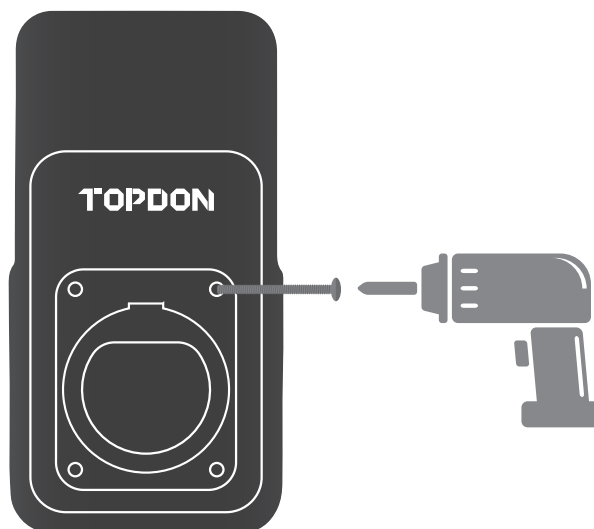

Fig. 5.6.4



Please put the charging plug back to the Charging Dock after each charge.

# Section 6—Network Configuration

## 6.1 Wi-Fi Configuration

1. To configure the Wi-Fi, please download the PulseQ application from the APP Store and Google Play and install the app to your phone. (See Figure 6.1.1)



Fig.6.1.1

2. Register an account with your email address and login. (See Figure 6.1.2)

3. Open the app and tap the User Center, select the charging station management. (See Figure 6.1.3)

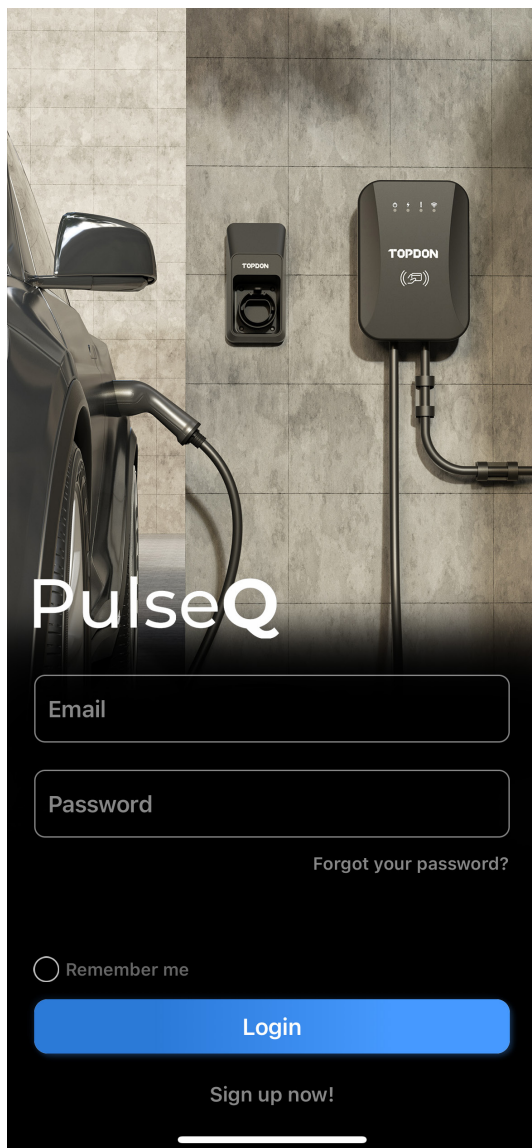

Fig.6.1.2

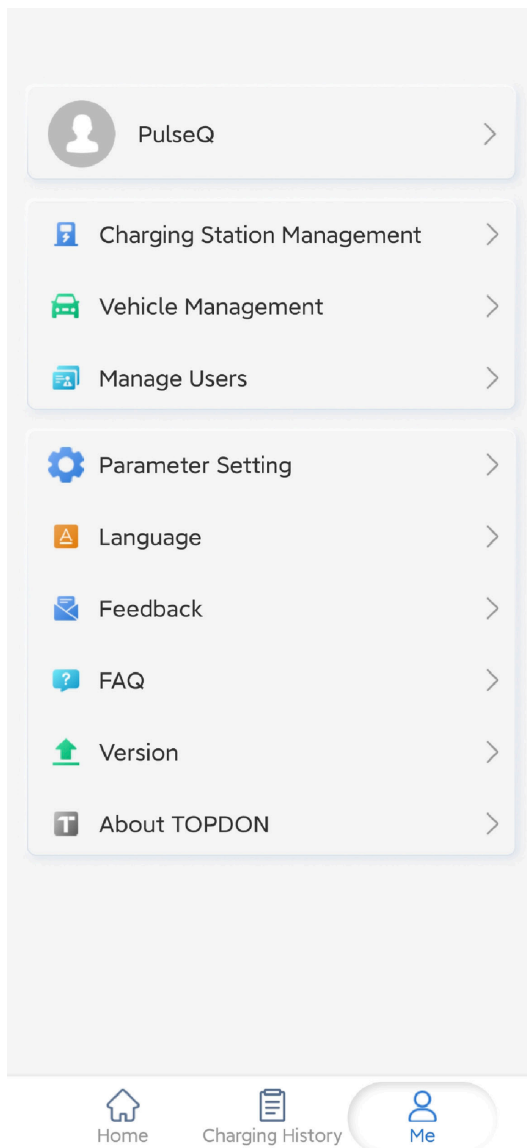

Fig.6.1.3



4. Tap the cross at the bottom right to add your charging station. (See Figure 6.1.4)

5. Select the Wi-Fi network. (See Figure 6.1.5)

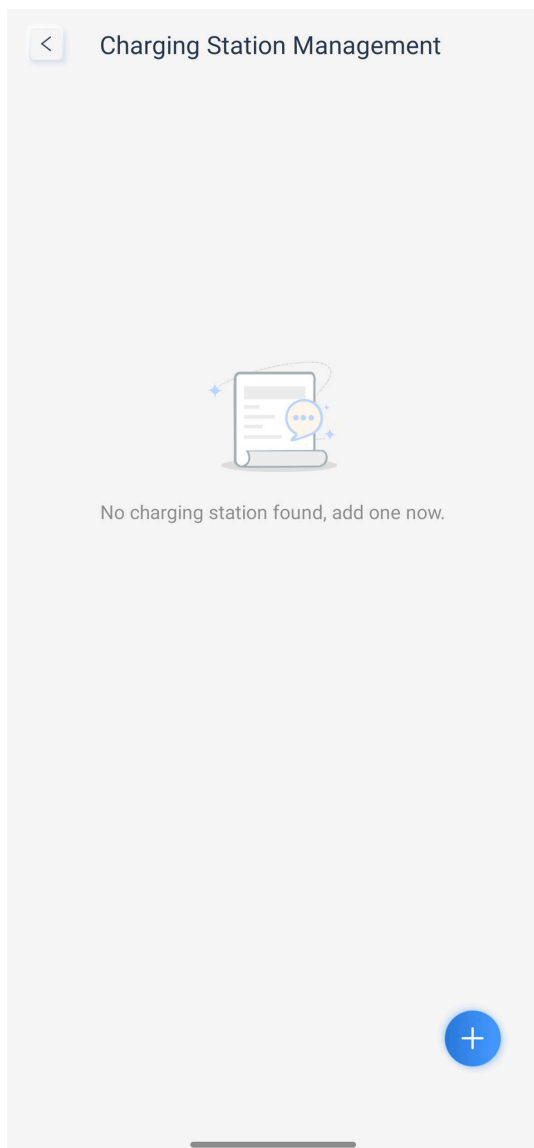

Fig.6.1.4

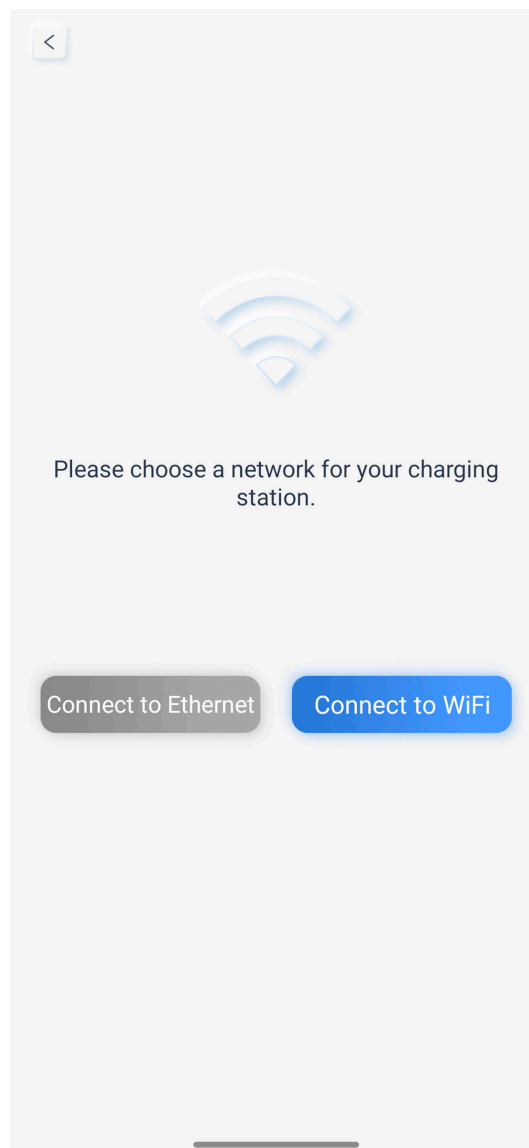

Fig.6.1.5

6. Scan the QR code on the side of the charging station. (See Figure 6.1.6)

7. Tap the button to bind your charging station. (See Figure 6.1.7)

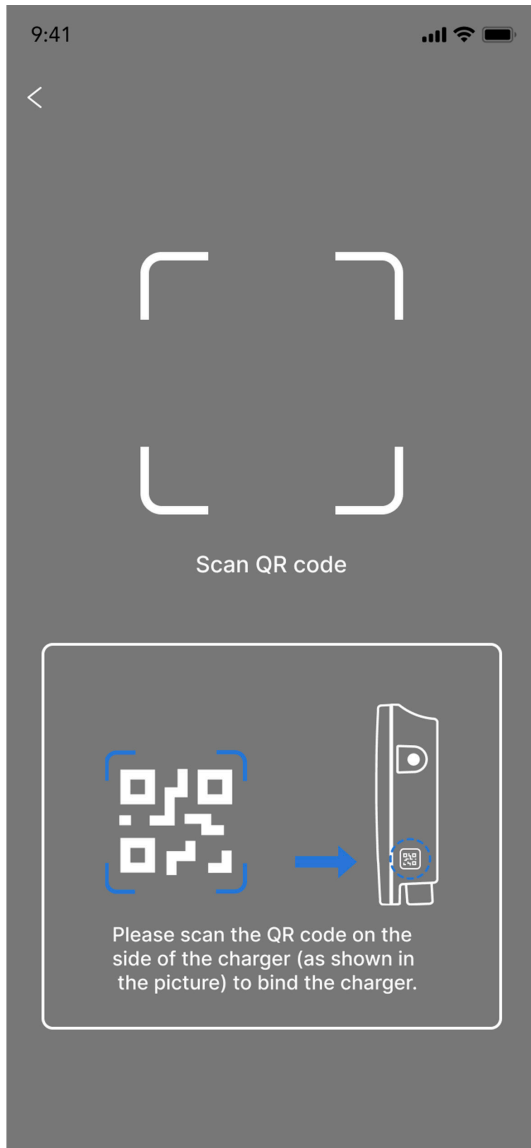

Fig.6.1.6

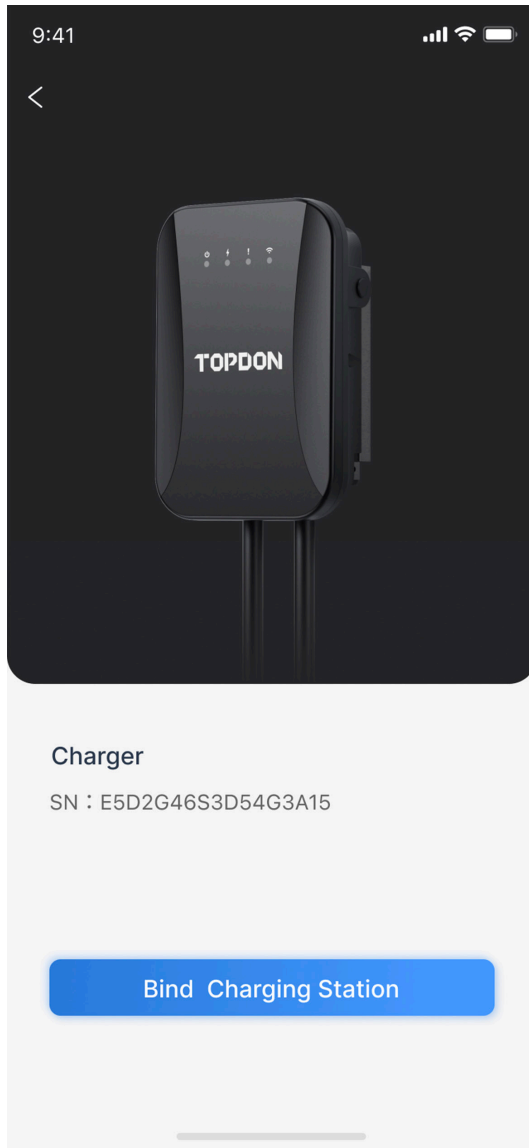

Fig.6.1.7

8. Enter the Wi-Fi name and password and tap Next. (See Figure 6.1.8)



Note: This charging station supports 2.4GHz Wi-Fi only.

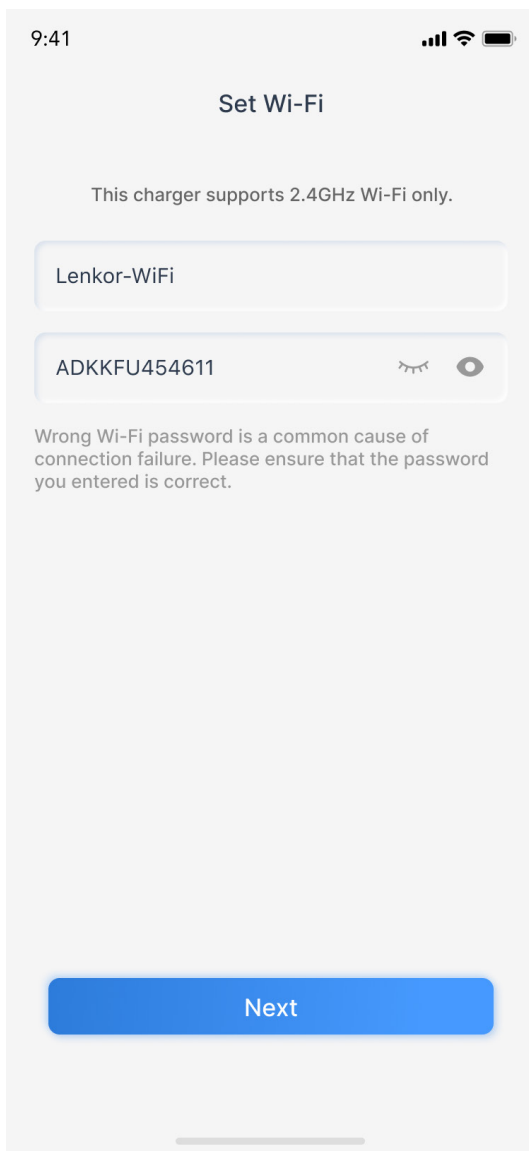

Fig.6.1.8

9. Ensure that the TOPDON-AC-Home can be detected in your available Wi-Fi list. Then, tap Hotspot Available, Connect. (See Figure 6.1.9)
10. Wi-Fi connection will be automatically proceeded. (See Figure 6.1.10)

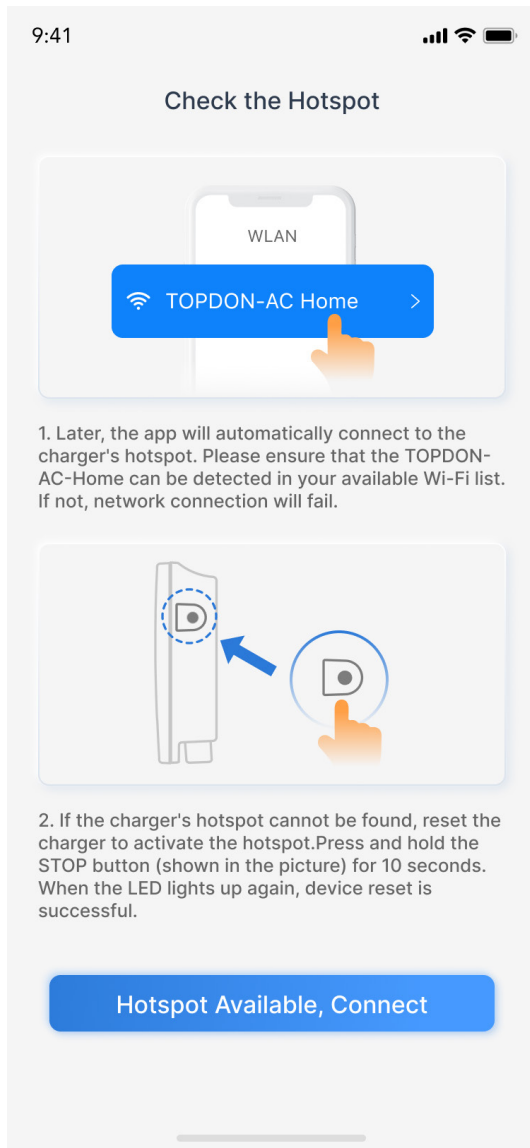

Fig.6.1.9

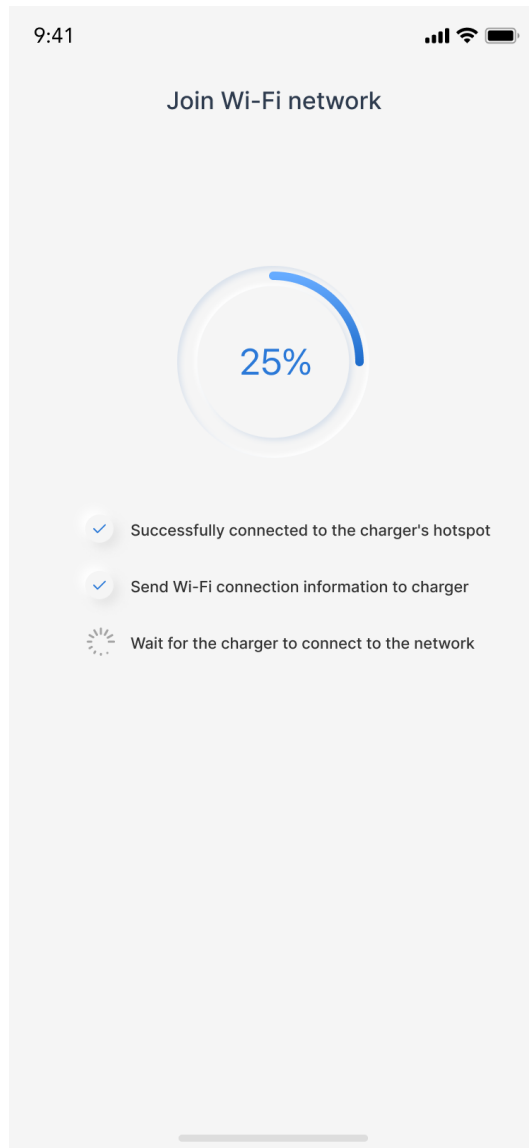

Fig.6.1.10

11. After successful connection, you can rename your charging station.(See Figure 6.1.11)

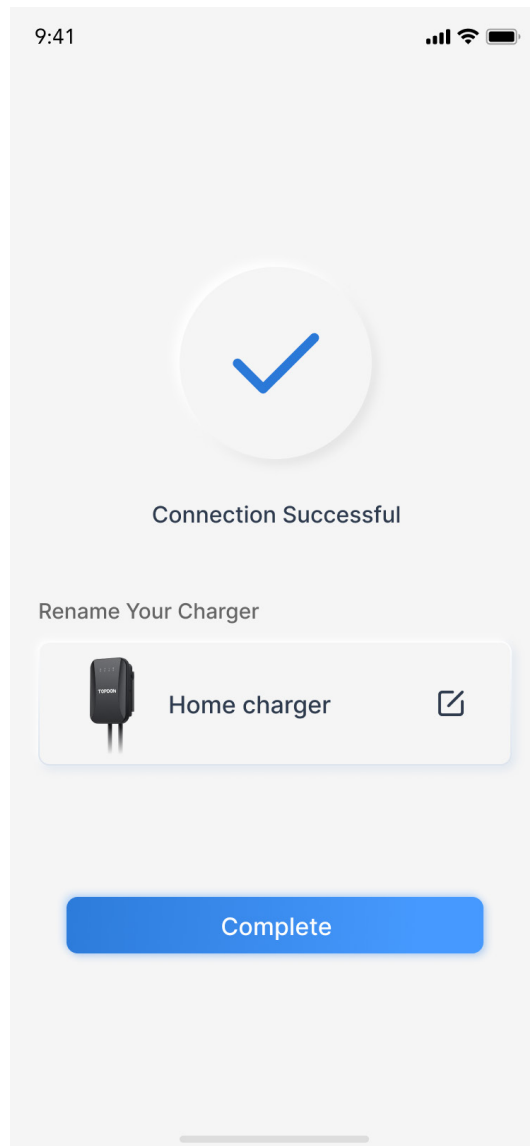





Fig.6.1.11

## Section 7—LED Indicators

The LED indicators on the panel are used to indicate the status of the charger and the various combinations of indicators are described as below.

No.	Icon	Indicator Color	Indicator Status	Connotation
1		Green	ON	Standby status
			Twinkle	Ground fault status
2		Green	ON	Connected to an EV
			BLN control	Charging status
3		Red	Twinkle	Fault status
				Twinkle frequency indicates the fault code
4		Blue	OFF	Unconnected network
			ON	Connected to the network
			ON	Exchange data with CMS via network.
			Twinkle	Configure WiFi network status

# Section 8—Fault Handling

If All LED are not on, please check:



- ▷ Whether the power supply and distribution are normal;
- ▷ Whether the branch breaker is tripped, and close the breaker after troubleshooting;
- ▷ Whether the connection is correct, if the cable comes off, should be properly connected to tighten the cable.

The charger is automatically protected in the event of the fault. The fault information and handling methods are as follows.

Indicator Twinkle	Fault Code	Handling Method
• 1×slow, 1×fast	<b>Fault code 11:</b> CP voltage anomaly	<ul style="list-style-type: none"> <li>• Check the connection of charging connector and EV socket.</li> <li>• Disconnect and reconnect the charging connector.</li> </ul>
• 1×slow, 3×fast	<b>Fault code 13:</b> Undervoltage input	<ul style="list-style-type: none"> <li>• Check whether the input cable is reliably connected.</li> <li>• Check whether the input voltage is abnormal.</li> </ul>
• 1×slow, 4×fast	<b>Fault code 14:</b> Overvoltage input	<ul style="list-style-type: none"> <li>• Check whether the input cable is connected correctly.</li> <li>• Check whether the input voltage is abnormal.</li> </ul>
• 1×slow, 5×fast	<b>Fault code 15:</b> Over-temperature protection	<ul style="list-style-type: none"> <li>• Check whether the charging station is covered or installed in a high temperature environment.</li> </ul>
• 1×slow, 6×fast	<b>Fault code 16:</b> Metering fault	<ul style="list-style-type: none"> <li>• Power off and restart the device.</li> </ul>
• 1×slow, 7×fast	<b>Fault code 17:</b> Leakage protection	<ul style="list-style-type: none"> <li>• Check whether the charging connector and its cable are damaged or wet.</li> <li>• Recover after pulling out the adapter.</li> </ul>
• 1×slow, 8×fast	<b>Fault code 18:</b> Output shortage	<ul style="list-style-type: none"> <li>• Check whether the charging adapter and its cables are damaged or wet.</li> </ul>
• 1×slow, 9×fast	<b>Fault code 19:</b> Output overcurrent	<ul style="list-style-type: none"> <li>• Check whether the charging connector is correctly connected.</li> <li>• Check whether the OBC is normal.</li> <li>Check the set of output current.</li> </ul>
• 2×slow, 1×fast	<b>Fault code 21:</b> EV response timeout	<ul style="list-style-type: none"> <li>• Battery of EV is full. Or the charging connector is not properly connected.</li> <li>• Disconnect and reconnect the charging connector.</li> </ul>
• 2×slow, 2×fast	<b>Fault code 22:</b> EV not supported	<ul style="list-style-type: none"> <li>• This EV does not meet the IEC standards and cannot be charged.</li> </ul>

• 2×slow, 3×fast	<b>Fault code 23:</b> Relay sticking	• The device is damaged and needs to be returned to the factory for repair.
• 2×slow, 4×fast	<b>Fault code 24:</b> RCD fault	• The RCD is damaged and needs to be returned to the factory for repair.
• 2×slow, 5×fast	<b>Fault code 25:</b> Ground fault	• Charging station is not grounded; input power cable needs to be checked.
• 2×slow, 6×fast	<b>Fault code 26:</b> Ground leakage current	• The ground cable has leakage current, and the charging pile needs to be restarted.

## Section 9—Warranty

### TOPDON's Limited Warranty

TOPDON warrants to its original purchaser that the company's products will be free from defects in material and workmanship for 24 months (charging station) and 12 month for (charging cable) from the date of purchase (Warranty Period).

For the defects reported during the Warranty Period, TOPDON will either repair or replace the defective part or product according to its technical support analysis and confirmation.

TOPDON shall not be liable for any incidental or consequential damages arising from the device's use, misuse, or mounting.

Some states do not allow limitation on how long an implied warranty lasts, so the above limitations may not apply to you.

This limited warranty is void under the following conditions:

- Misused, disassembled, altered or repaired by unauthorized stores or technicians.
- Careless handling and operation's violation.

Notice: All information in this manual is based on the latest information available at the time of publication and no warranty can be made for its accuracy or completeness. TOPDON reserves the right to make changes at any time without notice.







**TEL**

**86-755-21612590**



**EMAIL**

**SUPPORT@TOPDON.COM**



**WEBSITE**

**WWW.TOPDON.COM**



**FACEBOOK**

**@TOPDONOFFICIAL**



**TWITTER**

**@TOPDONOFFICIAL**

---

